

ecoHITCH -Designed Specifically For Your **Green Vehicle**

Installation Instructions

Application Fits
2012-2015 Subaru Impreza Hatchback
X7211 & X7212

DOES NOT FIT WRX MODEL

*Must have factory knockout

2" & 1.25" EcoHitch Invisi

350 lbs. Tongue Weight/3,500 lbs. Towing Weight

THERE ARE **TWO VERSIONS** INCLUDED FOR INSTALLATION.

VERSION 1: REQUIRES BUMPER REMOVAL. **Start On Page 2.**

VERSION 2: REQUIRES HOLE ENLARGEMENT. **Start On Page 5.**

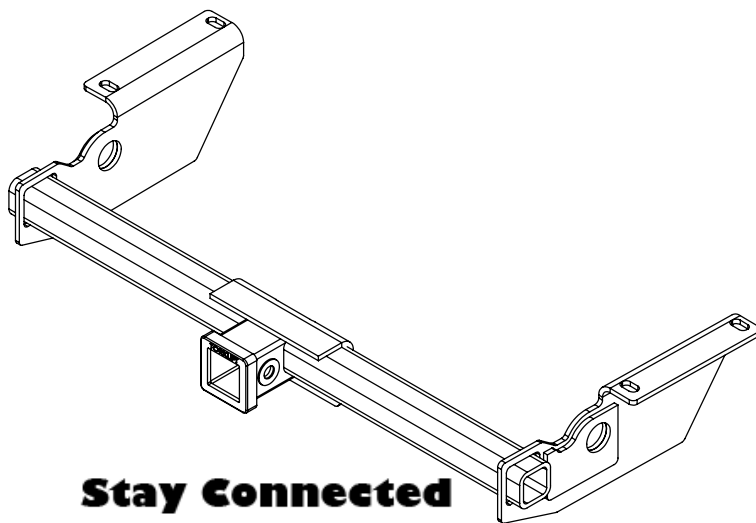

Stay Connected



torkliftcentral



torkliftcentral



tlcentral



torklift central



torklift central

Torklift Central
315 Central Ave N
Kent, WA 98032
253-854-1832

www.torkliftcentral.com
support@tlcentral.com



QTY	Fastener
8	1/2" Flat Washer
4	1/2" Lock Washer
4	1/2" Internal Tooth Star Lock Washer
4	1/2"-13 Grade 5 Nut
4	1/2"-13 x 2" Grade 5 Hex Bolts
4	1/2"D-1x2 Plate Washer
1	1/2" Bolt Fisher

Version 1: BUMPER REMOVAL METHOD

READ THESE INSTRUCTIONS THOROUGHLY AND ACCOUNT FOR ALL HARDWARE LISTED BEFORE BEGINNING INSTALLATION!

Step 1. Remove bolts from tail light assemblies and carefully pull rearward to remove then unplug the electrical connectors.

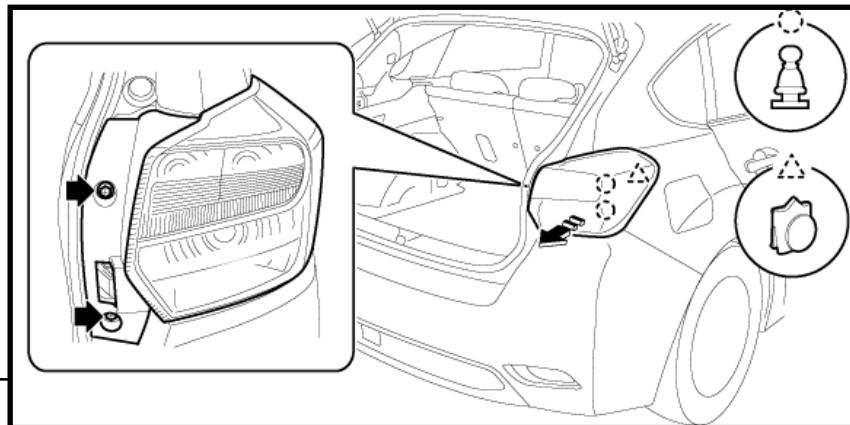

Fig. [1]

Step 2. Remove the (10) push clips shown in Figure [2]. Once removed begin to gently peel back bumper fascia starting at the passenger side wheel well working your way around to the back and finally to the driver side. **DO NOT USE EXCESSIVE FORCE.** Non-warranted damage may occur.

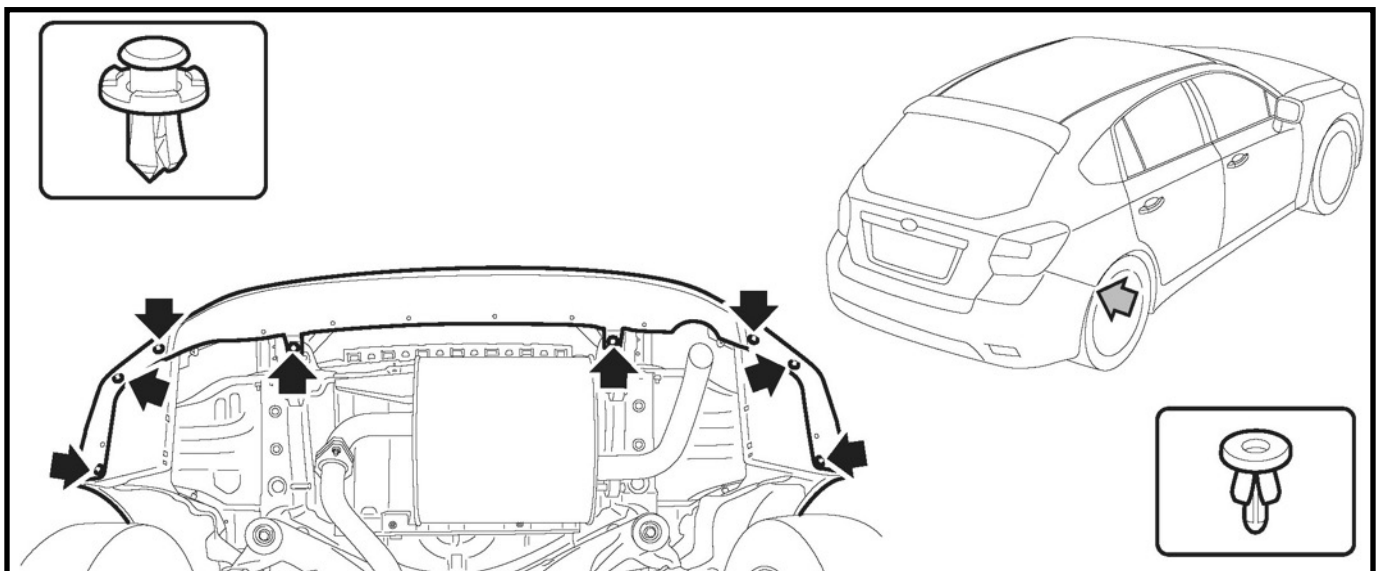

Fig. [2]

Step 3. Remove impact bar by removing the four bolts and two nuts holding the impact bar to the vehicle. Set aside for reinstallation. See Figure [3].

Step 4. Remove bumper fascia hangers. Note the direction of the hangers for reinstallation later. See Figure [3] for location.

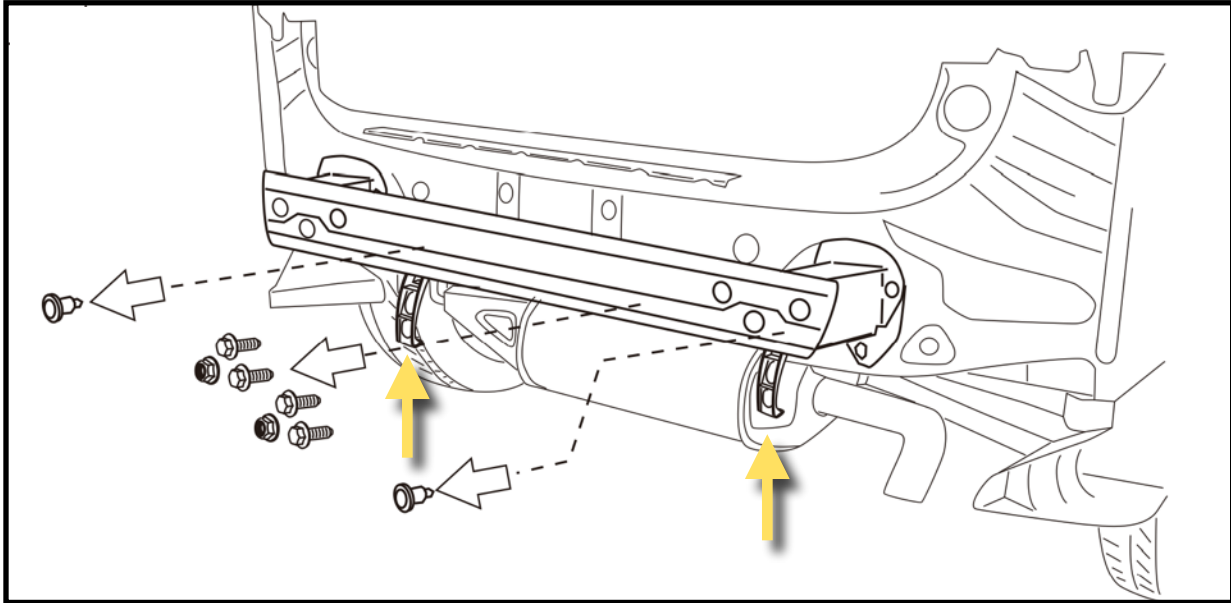

Fig. [3]

Step 5. Lower exhaust to create room for hitch installation by lubricating rubber exhaust bungs with WD-40 or equivalent. Be sure to support exhaust with a block of wood or other stand, and not let exhaust hang freely.

Step 6. Remove four rubber plugs (two on driver and passenger side each) in frame rails on underside of vehicle.

Step 7. Fish bolt hardware into frame rails by feeding coil end of bolt fisher through the forward most open hole in the driver side frame rail. Once coil is accessible from impact bar opening, attach one 1/2"x2" bolt, 1/2" internal tooth star lock washer, and 1x2 plate washer, and pull through frame rail to feed into position. Repeat on remaining driver side hole and both passenger side holes. See Figure [4] for assembly reference only. See Figure [5] for hardware hole placement reference.

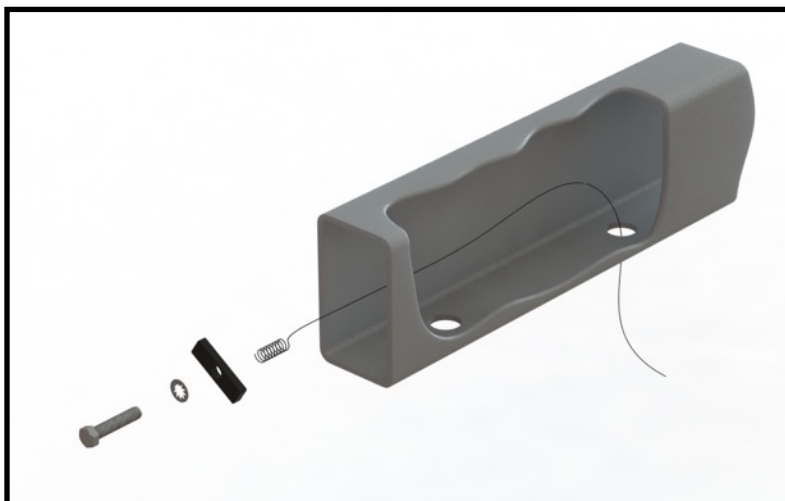

Fig. [4]

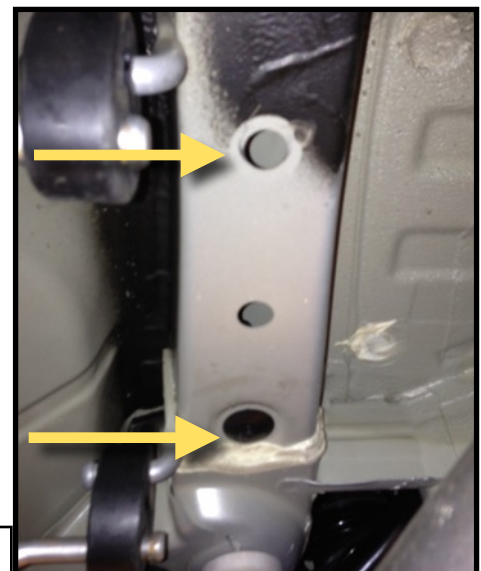

Fig. [5]

Step 8. With all hardware properly fished into position, raise hitch onto hanging hardware. Be careful not to push bolt hardware back into frame rails. Secure bolts with two 1/2" flat washers, one 1/2" lock washer, and one 1/2" nut. Once hitch is secured and centered on vehicle, torque all hardware to 75 ft-lbs.

Step 9. Reinstall rubber exhaust bungs by re-lubricating and placing back onto hangers. impact bar and torque hardware to 55 ft-lbs.

Step 10. Reinstall bumper fascia hangers by turning 180 degrees and securing back to frame. This will allow hangers to curl around the hitch cross tube and the bumper to be properly secured.

Step 11. Using a utility knife or air-saw, trim the portion as shown in Figure [6] of the bumper fascia behind the fog light knockout panel. Make sure to keep the lower tab slots and side tabs as shown to allow the knockout to be reinstalled.



Fig [6]



Step 12. Reinstall bumper fascia reusing the removed push pin clips. Reinstall the light assemblies.

Congratulations on the completed installation of the Subaru Impreza Hatchback Invisi Hitch! It is designed with a lifetime warranty for a lifetime of enjoyment. If you have any questions or suggestions please contact our tech support at support@tlcentral.com or by phone at (253) 854-1832.



Version 2: HOLE ENLARGEMENT METHOD

READ THESE INSTRUCTIONS THOROUGHLY AND ACCOUNT FOR ALL HARDWARE LISTED BEFORE BEGINNING INSTALLATION!

Step 1. Raise rear of vehicle off of ground and place on ramps or suitable jack stands.

Step 2. Locate the rubber plugs in the frame rail under the vehicle on the driver and passenger side and remove the two outer plugs. See Figure [1].



Fig [1]

Step 3. Remove the knockout panel in the center of the lower bumper fascia using a flat headed tool. Be cautious as to not scratch or damage the reusable panel. See Figure [2].

Step 4. Using a utility knife or air-saw, trim the portion as shown in Figure [3]. Make sure to keep the lower tab slots and side tabs as shown to allow the knockout to be reinstalled.



Fig [6]



Step 5. Open the rear hatch of the vehicle and remove the carpet liner from the rear of the vehicle and the styrofoam inserts.



Fig [4]

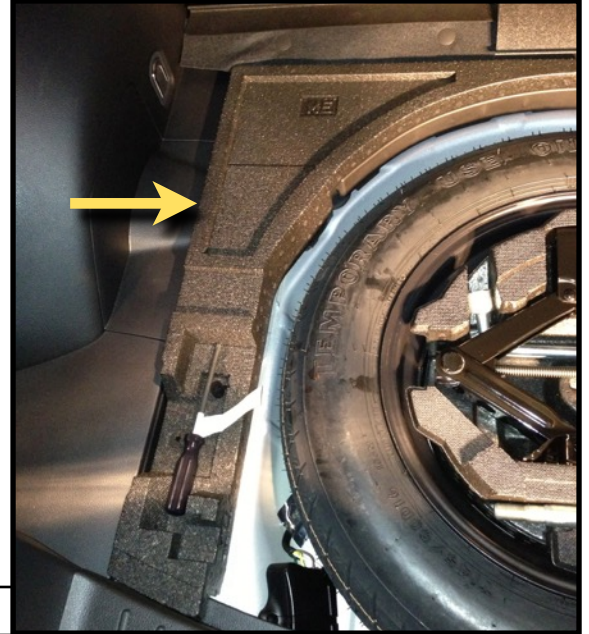

Fig [5]

Step 6. Locate the two black plastic stickers on each side of the spare tire compartment. The dashed arrows below show their location. Carefully remove the stickers on the driver and passenger side so that they can be reused later. See Figure [6].

Step 7. Although you will not be drilling into the frame, you will need to enlarge the hole noted by the solid arrow in Figure [6]. This will allow the bolts to pass through the trunk pan into the frame of the vehicle. Using a dremmel tool, tin snips, or wire cutters, enlarge the hole enough so that you can fit the 1x2 plate washer through. You will repeat this process on the opposite side of the vehicle. See Figure [6].

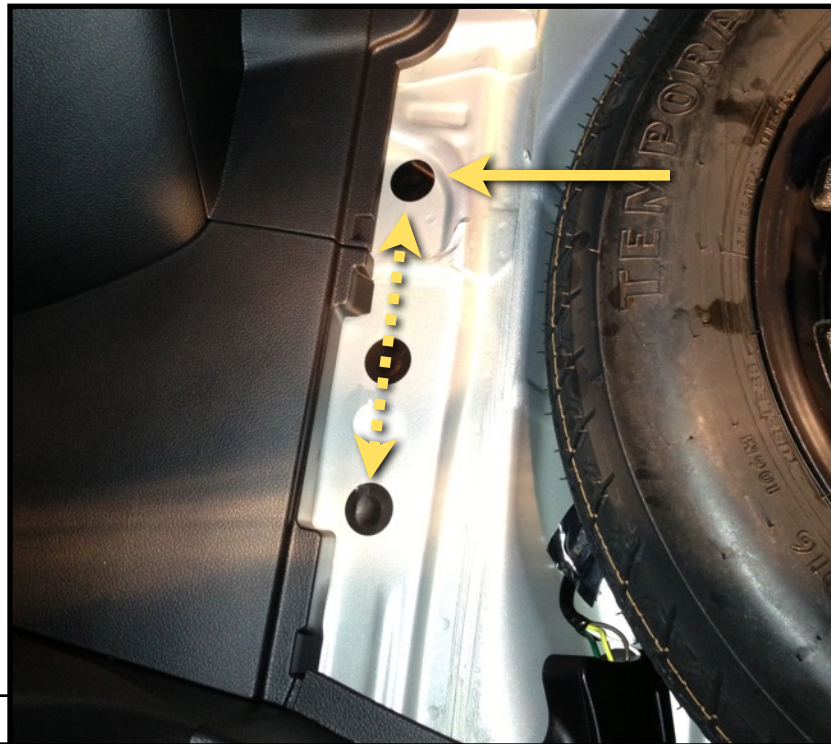

Fig [6]

Step 8. Feed the coil end of the boltfisher carefully into the rearmost bottom frame rail hole and up through the topside enlarged hole. Once fished, attach one 1/2"x2" grade 5 bolt, one 1/2" internal tooth star lock washer, and one 1x2 plate washer and pull on the boltfisher to pull hardware into position. Repeat for remaining driver side hole and both passenger side holes. See Figure [7] & [8] for reference.

TIP: When pulling hardware through, feed the 1x2 plate washer through first and then pull the rest of the assembly into place.

NOTE: You must fish this bolt into position first. Failure to do this may not allow the second hitch bolt to pass through the frame.

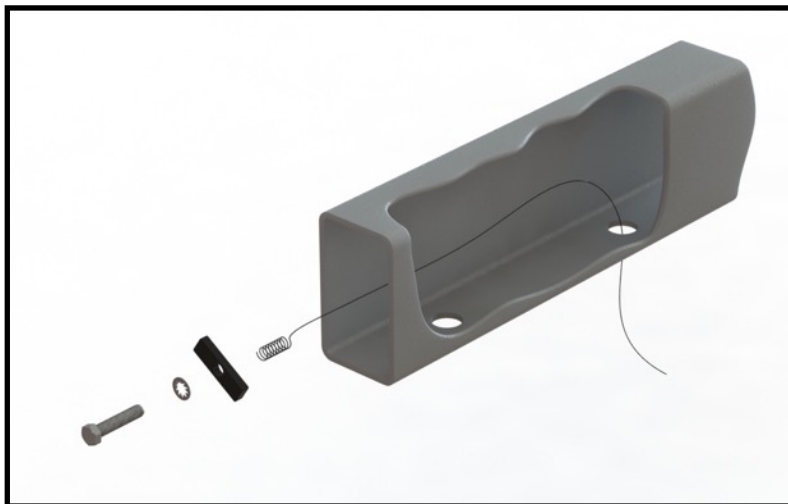

Fig [7]



Fig [8]

Figure [9] shows a successful fished bolt with the 1/2"x2" bolt head resting on top of the 1/2" internal tooth star lock washer and 1x2 plate washer, through the frame rail holes.



Fig [9]

Step 10. Lower the exhaust by removing five total rubber exhaust bungs (two driver, two passenger, and one central location). Use a lubricant such as WD-40 to assist in removal and support exhaust with a wood block or other stand so the exhaust does not hang. Figures and arrows below will show locations.

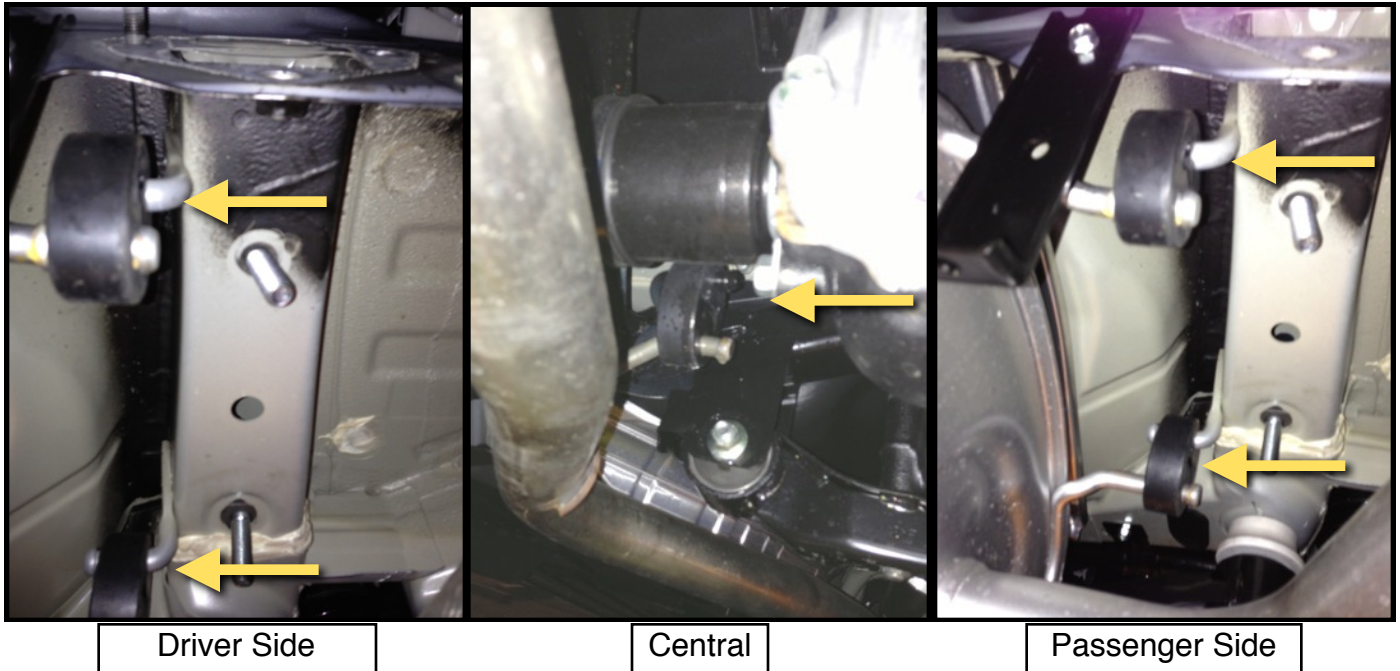

Step 11. Disconnect the two bumper hangers shown in Figure [10] and set aside for reinstallation. Gently pull down the bottom lip of the bumper fascia and raise the hitch into position on bolts. Once the hitch is in position on the bolts place two 1/2" flat washers, one 1/2" lock washer and one 1/2" hex nut onto each bolt. With hitch centered behind the knockout panel, torque the four 1/2" hex nuts to 75 ft-lbs. Reinstall bumper brackets by turning 180 degrees so that they curl around the hitch cross tube. See Figure [11].

CAUTION: Be careful when placing hitch onto bolts that you do not push the bolts back into the frame rails. Having an extra pair of hands to assist in this step is advised.

Fig [10]



Fig [11]



Step 12. Raise the exhaust and re-attach exhaust hangers. Re-lubricating the exhaust bungs will ease their reinstallation.

Step 13. Replace the stickers that were removed in Step 6. If stickers can not be reapplied, it would be acceptable to use electrical tape or duct tape. Re-install styrofoam inserts and carpet liner.

Congratulations on the completed installation of the Subaru Impreza Hatchback Invisi Hitch! It is designed with a lifetime warranty for a lifetime of enjoyment. If you have any questions or suggestions please contact our tech support at support@tlcentral.com or by phone at (253) 854-1832.

FINISHED PRODUCT



IMPORTANT INFORMATION

Due to the Invisi style of this hitch, all ballmounts/bike rack stingers cannot exceed more than 2-3/8" of an inch from the center of the pinhole to the end of the stinger. Failure to do so will cause ballmount/bike rack stingers to not fit or cause NON WARRANTIED damage to the exhaust system.

To make your ballmount or bike rack fit, you can shorten the stinger to allow it to fit properly with the Invisi hitch.

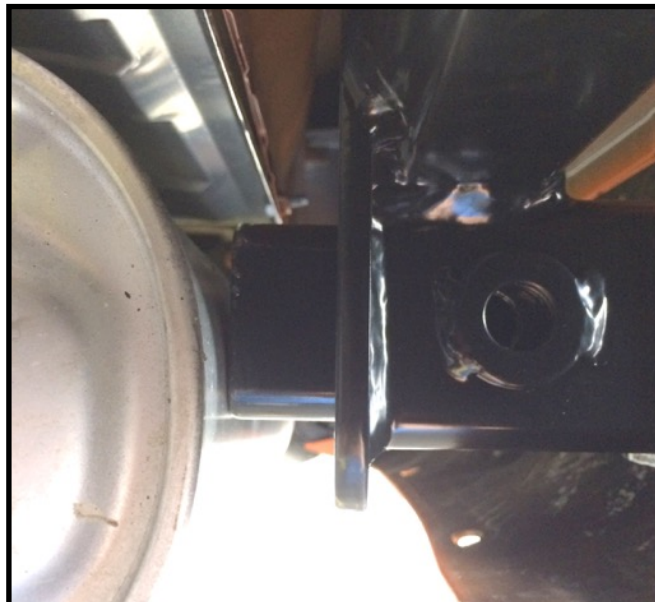

EXAMPLE: Ballmount stinger is too long causing the ballmount to hit the exhaust.

WARRANTY/DISCLAIMER INFORMATION

Torklift Central requires proof of purchase for warranty claim registration, with pictures of any defective product before issuing a replacement. Torklift will not accept claims on any product without proof of purchase, which can be faxed, scanned, emailed or mailed to the information provided below. Torklift Central warrants its hitches, custom hitch receivers and accessories (excluding electrical wire harnesses which carry a warranty from their specified manufacturer) from date of purchase against defects in material and workmanship under normal use and service for the ownership life of the original consumer purchaser. Torklift Central will replace free of charge any part that proves defective in material or workmanship when presented to Torklift Central, transportation charges prepaid by purchaser, at the address below. **This warranty is limited to defective parts replacement only. Labor charges and/or damage incurred in installation or replacement, as well as incidental and consequential damages connected therewith are excluded.** This warranty does not include normal wear and tear or the finish and paint. Rusting, cracking or peeling of the finish is also excluded. Some states do not allow the exclusion or limitation of incidental or consequential damages, so the above limitation or exclusion may not apply to you. Any damage to Torklift Central products as a result of misuse, abuse, neglect, accident, improper installation or any use violative of instructions furnished by Torklift Central will void the warranty. This warranty gives you specific legal rights and you may also have rights, which vary from state to state. With warranty service, you may be able to go to a small claims court, a state court or a federal district court.

Although Torklift Central trailer hitches are both tested and rated for towing within the specific capacity label found on each trailer hitch. Torklift Central assumes no liability for vehicle manufacturers warranty due to the use of a Torklift Central trailer hitch being used for towing behind any vehicle or using the trailer hitch in a manner that it was not designed for. Although this specific trailer hitch has a load rating, which includes trailer tongue weight, and a trailer weight carrying capacity, Torklift Central is not responsible for the voiding of any warranty on any vehicle due to factory towing limitations. All vehicle warranties are the sole property and responsibility of the owner of the vehicle that the Torklift Central trailer hitch is installed upon. Torklift Central does not endorse towing behind any vehicle if the vehicles manufacturer states that towing is not recommended. Check your vehicle's owner's manual for the proper tow rating of your vehicle.

ADDRESS: 315 Central Ave N. Kent, WA 98032

WARNING Your vehicle may have a lower tow rating than this trailer hitch. If your vehicle's tow rating is less than the rated towing capacity on your Torklift Central trailer hitch, your trailer hitch capacity is limited to your vehicle's factory rated towing capacity.

FOR EXAMPLE: the label on your Torklift Central trailer hitch states it's capacity is rated for 500 pounds tongue weight and 5,000 pounds towing weight. However your vehicle's factory rated towing capacity is limited to only 350 pounds tongue weight and 3,500 pounds towing weight. In this example your maximum towing capacity of your Torklift Central trailer hitch is limited to 350 pounds tongue weight and 3,500 pounds towing weight as stated by your vehicle's maximum factory tow rating.

DANGER Never exceed your vehicle's manufacturer's recommended towing capacity which may be a lower rating than this trailer hitch

Unsure of your tow rating? Download our towing app from the app store to find your vehicles tow rating.
www.torkliftcentral.com/app.php